

# ISUZU

## SPECIFICATIONS

### FRR 107-210 TIPPER

Now with  
Sat Nav fitted  
as standard\*



\* Satellite Navigation functions and maps provided at no extra cost, with up to four quarterly updates provided by user free download for the first three years of ownership, after which updates can be purchased at additional cost.

**AUSTRALIA'S TOP SELLING TRUCK BRAND SINCE 1989.**

#### AT A GLANCE\*

GVM	10,700 kg
GCM	16,000 kg
Power	154 kW @ 2,400 rpm
Torque	726 Nm @ 1,600 rpm

\* Refer to back page for detailed weight rating information

#### ADVANCED TECHNOLOGY

Emissions: Japan PNLT / ADR 80/03

Low and high pressure sequential turbochargers

Driver and passenger airbag with seatbelt pretensioner

ECE-R29 compliant cab

Anti-lock Braking System (ABS)

Idle stop system (ISS)

Anti Skid Regulator (ASR)

Hill Start Aid (HSA)

Electric mirrors

Front stabiliser bar

Cruise control

ISRI 6860 driver seat with integrated seatbelt

Cornering lamps



# ISUZU TRUCKS

## DRIVELINE AND CHASSIS SPECIFICATIONS

### ENGINE: ISUZU N-4HK1-TCS

**Type:** 4 cylinder 16 valve SOHC  
**Displacement:** 5,193 cc  
**Compression Ratio:** 16.5:1  
**Bore x Stroke:** 115 mm x 125 mm  
**Max power (DIN-NET):** 154 kW (207 HP) @ 2,400 RPM  
**(JIS Gross):** 159 kW (213 HP) @ 2,400 RPM  
**Max torque (DIN-NET):** 726 Nm (535 lb.ft) @ 1,600 RPM  
**(JIS Gross):** 751 Nm (554 lb.ft) @ 1,600 RPM

**Induction system:** Low pressure turbocharger and high pressure Variable Geometry System (VGS) turbocharger sequentially operated and with air-to-air intercooler.

**Fuel injection:** Direct injection high pressure common rail system. Exhaust pipe fuel injection for DPD regeneration.

**Emission control system:** Cooled EGR with exhaust Diesel Particulate Diffuser (DPD). ADR 80/03 (Japan PNLT) compliant.

### CLUTCH

#### Standard model:

- Air assisted hydraulic control. Single plate 352 mm diameter.
- Total lining area: 1,164 cm<sup>2</sup>

#### AMT model:

- Fully automated hydraulically controlled wet clutch and torque convertor with lock up.

### TRANSMISSION

#### ISUZU MZW-6P

- Synchromesh on gears 2-6. Triple cone synchromesh on 2nd and 3rd gears. Integral oil pump provides full pressure lubrication.
  - Gear ratios (:1)
- | 1st   | 2nd   | 3rd   | 4th   | 5th   | 6th   | Rev   |
|-------|-------|-------|-------|-------|-------|-------|
| 6.615 | 4.095 | 2.358 | 1.531 | 1.000 | 0.722 | 6.615 |

#### Standard model:

- 6 speed manual with air assisted shift.

#### AMT model:

- 6 speed Automated Manual Transmission (AMT) with both fully automatic and clutchless manual operation modes.

### AXLES

#### Front: Isuzu F041

- Reverse Elliot I-beam. 4,100 kg capacity.

#### Rear: Isuzu R077

- Full floating Banjo type. 7,700 kg capacity.
- Drive ratio: 4.875:1

### SUSPENSION

#### Front:

- Single stage alloy steel multi-leaf springs.
- Double acting hydraulic shock absorbers. Stabiliser bar.

#### Rear:

- Multi-leaf main spring, multi-leaf helper spring.

### BRAKES

- Dual circuit air over hydraulic front and rear drum brakes.
- ABS, ASR traction control.
- Hill Start Aid (HSA).
- Front drum size: 320 x 120 mm
- Rear drum size: 320 x 145 mm
- Spring park brake.
- Air controlled exhaust brake.
- Air dryer.

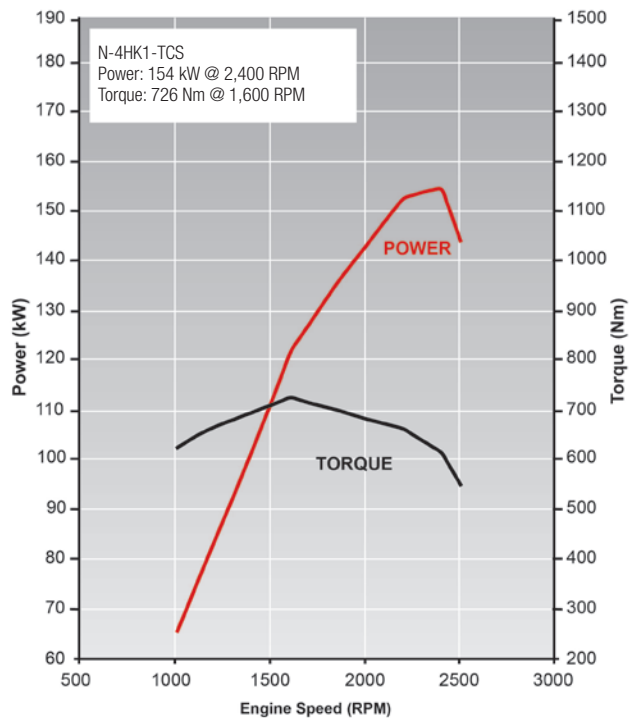

### STEERING

- Power assisted recirculating ball steering.
- Gear ratio: 16:1 - 18.8:1
- Turns lock to lock: 4.1
- Maximum angle: 52° (inside wheel) / 39° (outside wheel)

### WHEELS AND TYRES

- 17.5 x 6.00J six stud steel wheels.
- **Steer axle:** 9.5R17.5 129/127L Michelin X Multi Z Tubeless.
- **Drive axle:** 9.5R17.5 129/127L Michelin XZY Tubeless.
- Maximum tyre rating:
  - Steer axle:** 3,700 kg
  - Drive axle:** 7,000 kg
- Spare wheel and tyre assembly supplied.

### CHASSIS FRAME

- Cold rivetted ladder frame with parallel side rails. HT540A high tensile weldable steel sidemembers.
- Frame dimensions:
  - Side rail (mm): 225 x 70 x 6.0
  - Rear frame width (mm): 840

### TIPPER BODY

- All steel body with drop sides. Auto release two-way tailgate.
- Auto release body lockdown hook.
- Shovel rack. LHS and RHS rope rails. Non-slip side steps.
- 20 second raise / 20 second lower time.
- Cubic volume: 3.8 m<sup>3</sup>
- Deck plate thickness: 6.0 mm
- Side / front / tail plate thickness: 3.2 mm

### FUEL TANK

- Frame mounted 200L steel fuel tank.
- Lockable fuel cap.

## ELECTRICAL SYSTEM

- 24 volt electrical system.
- 90 amp alternator.
- 24 volt, 5.0 kW starter motor.

## CABIN SPECIFICATIONS AND APPOINTMENTS

### CAB EXTERIOR

- All steel construction. High tensile steel used for cab underframe. Manual cab tilt to 45° with torsion bar assistance.
- Complies with ECE-R29 cab strength standard.
- Liquid filled front and rear cab mounts.
- Heavy duty non slip entry steps.
- 90° opening internally reinforced front doors.
- Water spray suppression guards and front mudflaps.
- Laminated windscreen with shade band.
- Two speed windscreen wipers, with intermittent wipe mode.
- Halogen multi-reflector headlamps incorporating turn signals. Additional door mounted integrated side indicator/cornering lamps.
- Combination brake, turn, reverse and marker lamps, registration plate illumination lamps. Reverse alarm.
- Roof mounted clearance lamps.
- Heated and powered exterior main mirrors with flat glass and additional powered convex "spot" mirrors.
- Body coloured grille.
- Body coloured steel bumper with front foglamps.

### CAB INTERIOR

- Isri 6860 air suspension driver's seat with pneumatic lumbar support, height, rake and automatic weight adjustment.
- Front passenger adjustable bucket seat and front centre seat with folding seat back.
- 3-point lap sash seatbelts in all outboard seating positions. Driver seatbelt with pretensioner integrated with driver seat. Outboard front passenger seatbelt fitted with pretensioner. Centre seat lap belts.
- Driver and outboard front passenger airbag.
- **AMT model:** Driver's footrest.
- Door and roof pillar entry assist grips.
- Full interior trim, padded roof lining and vinyl floor covering. Driver and passenger windscreen header storage shelf.
- Tilt/Telescopic adjustable steering column, soft feel urethane steering wheel.
- Electric windows.
- Central locking with remote keyless entry and immobiliser.
- Twin cup holders. 24V cigarette lighter. Dashboard hook.
- Front door mounted storage pockets and driver's side ashtray.
- Centre console box with storage tray. Fold down storage tray behind centre seat backrest.
- Fully integrated air conditioning and heater/demister with 4-speed fan and outlets for windscreen, side windows, face and floor.
- Fluorescent type interior lamp with On/Door/Off switch.
- 2 DIN, two speaker multimedia unit with 6.2" LCD capacitive touch screen. 1.6GHz processor with Android operating system. DAB+ digital radio and fully integrated Bluetooth with voice recognition. Inbuilt PDF, photo and movie viewer. Internet radio accessible via smartphone. 32GB internal file storage. USB and auxilliary input connection provisions. Firmware and map updates possible via smartphone.
- DIN sized compartment for storage or for CB radio installation.

### ISUZU SATELLITE NAVIGATION

Integrated with multimedia unit. Displayed information includes:

- Points of interest and Isuzu truck dealer locations.
- Road safety alerts.

- 2 x 115E41L (651 CCA) batteries connected in series.
- Underdash CAN interface unit and connector. SAE J1939 protocol. Facilitates connection to a Fleet Management System (FMS) (not supplied).

- Speed limits and traffic signals.

- Route selection based on entered information such as vehicle weight and dimensions.

### DRIVER CONTROLS

- Key-operated engine start/stop and steering lock. Engine idle speed control.
- HSA slow/fast engagement control and on/off switch.
- ASR on/off.
- Idle stop system on/off.
- DPD regeneration.
- **AMT model:** AMT slow/fast gear engagement control, 1st gear start and normal/economy gear selection modes.
- **AMT model:** Gear selection control with R-N-D and sequential shift positions.
- **Left side combination stalk:** Windscreen wipers, washers and exhaust brake.
- **Right side combination stalk:** Turn signals, headlamps and cruise control.
- PTO engage switch.
- Tip body raise and lower lever with safety release mechanism.

### INSTRUMENTATION

- Electronically driven speedometer and tachometer. Digital odometer with integrated dual tripmeter. Engine coolant temperature, fuel level and air pressure gauges.
- **Warning lamps:** Check engine, oil pressure, low coolant level, ABS, SRS airbag, alternator charge, service brakes, park brake, seat belt unfastened, low air pressure, low fuel level, cab lock. **AMT model:** Check AMT.
- **Indicator lamps:** HSA, warm up system, high beam, ASR, DPD status, exhaust brake, turn signals, cruise control, PTO engaged. **AMT model:** Econo-mode, 1st gear start.
- **AMT model:** Gear selection display.
- Multi-information display. Shows service intervals, vehicle systems status, instantaneous and average fuel consumption, DPD bar chart, hourmeter, voltmeter, time/day/date and includes 40-120km/h adjustable vehicle speed warning.

### OPTIONS AND GENUINE ACCESSORIES

Include the following (extra cost, request a brochure and further details from your Isuzu dealer):

#### Multimedia unit:

- Supports up to five camera inputs. One low light capable digital camera and rear microphone input active when reversing. Four analogue cameras.
- Reversing sensors.
- Tyre pressure monitoring system.

#### Other:

- Airbag compatible bullbar.

## ISUZU CARE

Isuzu Care gives truck owners access to products and services including Roadside Assist, Service Agreements, Extended Care, Extended Isuzu Assist and the Isuzu Care Centre. Call 1800 035 640.

### WEIGHTS (kg)

Models	Ratings*		Loading Limit* (at ground)		Weight #		
	GVM	GCM	Front	Rear	Front	Rear	Total
FRR 107-210 TIPPER	10,700**	16,000	3,700	7,000	2,490	2,110	4,600
FRR 107-210 AMT TIPPER	10,700**	16,000	3,700	7,000	2,510	2,115	4,625

\* Vehicle ratings and front/rear weight limits are subject to government regulatory requirements and weight distribution analysis. \*\* Optional 8,000kg GVM rating available. Consult your Isuzu dealer to select the correct vehicle for your specific application.

# Vehicle as supplied and including 10 litres of fuel.

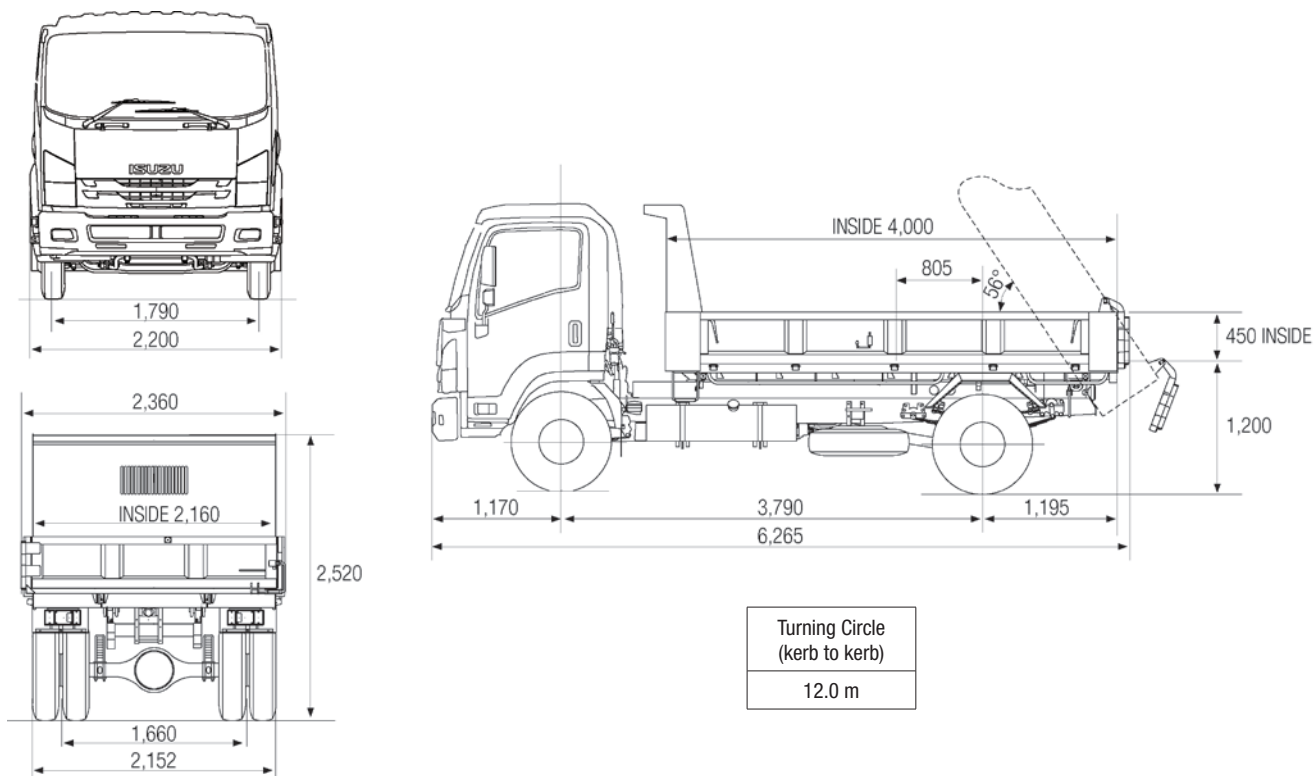

Turning Circle  
(kerb to kerb)

12.0 m

### PERFORMANCE (calculated - typical paved road)

		Geared Speed* (top gear at peak power engine RPM)	Low Speed Gradeability (lowest forward gear assuming no wheel slip)	Engine Speed (top gear at 100km/h)
FRR 107-210	At 10,700 kg GVM	105 km/h @ 2,400 RPM	49%	2,275 RPM

\*Maximum speed achievable depends on vehicle frontal area as well as other factors. Consult your Isuzu dealer for more detailed information. Vehicle is speed limited to 100km/h.

### ISUZU WARRANTIES

#### STANDARD<sup>1</sup>

New Vehicle 3 years • 150,000km • 2,500 hours

Cab Perforation Corrosion 3 years • unlimited km

Isuzu Assist: 24 hour roadside assistance (3 years, unlimited km)\*

#### EXTENDED CARE<sup>2</sup>

Extended Warranty: 5 years • 300,000km • 5,000 hours

Isuzu Assist: 24 hour roadside assistance (5 years, unlimited km)

### ORDER CODES

Model	Code
FRR 107-210 TIPPER	FH-FRRZD-A20
FRR 107-210 AMT TIPPER	FH-FRRZD-F20

<sup>1</sup> Subject to the conditions outlined in the IAL New Vehicle Warranty, the Isuzu FRR model carries a standard factory warranty which covers the owner: (i) for the entire vehicle, for the first 36 months or 150,000 km or 2,500 hrs (whichever comes first), (ii) against cab perforation corrosion, for 36 months and unlimited kilometres. <sup>2</sup> Extended Warranty as illustrated may be purchased to cover the owner against the failure of original components, but may exclude some components and expendable items such as oil, filters, etc. \*Valid for three years from the date of new vehicle purchases. All Isuzu warranties are subject to mandatory prescribed terms under Australian Consumer law including customer guarantees. For more details visit the Isuzu website which explains Isuzu warranties in more detail, or alternatively contact your local dealer. All warranties commence from date of delivery.

ISUZU AUSTRALIA LIMITED ABN 97 006 962 572 ("IAL"). The information in this spec sheet was correct at time of printing, but all measurements, specifications and equipment are subject to change without notice. Some equipment may have been changed and/or is available at extra cost. IAL may make changes at any time without notice, in prices, colours, materials, equipment and models. IAL makes all reasonable attempts to ensure the availability of all vehicles and equipment. The information in this spec sheet is general in nature. Your Isuzu dealer can confirm all measurements, specifications and vehicle / equipment availability upon request. To the extent permitted by the law, IAL is not liable to any person as result of reliance on the content of this spec sheet.